

# GUARDIAN/GUARDIANX SERIES DP53 480 VOLT 3-PHASE NEMA 4 or 4X AIR CONDITIONERS

Model	NEMA Rating	UL/CUL Listed or Recognized	BTU/H Rating	95/95 Rating	Ambient Temp.				Volts	Hz	* Running Amps	Weight lbs kg
					°F		°C					
					Max.	Min.	Max.	Min.				
K3NA6C18DP53L	4	Listed	18000	15800	125	-20	52	-29	480	60	5.7	224 102
K3NA6C18DP53LV	4X	Listed	18000	15800	125	-20	52	-29	480	60	5.7	224 102

\* Rating shown is for operation at maximum ambient temperature.

## STANDARD FEATURES

- Baked Powder Finish (NEMA 4 models)
- Closed-Loop Cooling
- Condenser Blower Controller
- Epoxy-Coated Condenser Coils
- External junction box for permanent wiring connections
- Filters (2)
- Heavy-duty Steel Shell
- Internal Corrosion Protection (NEMA 4X models)
- Low Temperature Control Thermostat
- NEMA 4 or 4X Rating Maintained (UL50)
- Stainless Steel Shell (NEMA 4X models)
- UL/CUL Listed
- Zero ODP Refrigerant

## ACCESSORIES AND OPTIONS

- Compressor Short Cycle Protector\*
- Enclosure Heater
- Filter Recoating Adhesive
- Lead-Lag Controller
- Programmable Temperature Alarm
- Programmable Thermostat Available
- Remote Thermostat Relay
- Replacement Filters
- Special materials or finishes
- Special motors, line cords or connectors
- Temperature Alarm

\* Standard Feature on models with a Programmable Thermostat



**NEMA  
TYPE 4 OR 4X  
MAINTAINED**



- ① CONDENSER AIR INLET (Ambient Air In)
- ② CONDENSER OUTLET (Warm Ambient Air Out)
- ③ WARM AIR RETURN FROM ENCLOSURE
- ④ COOL AIR OUTLET TO ENCLOSURE

## PERFORMANCE

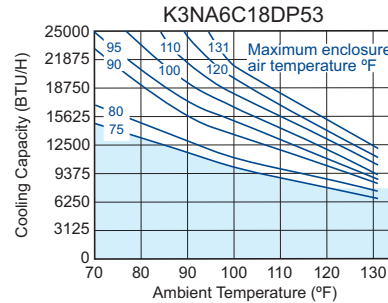

Operation within shaded area not recommended.

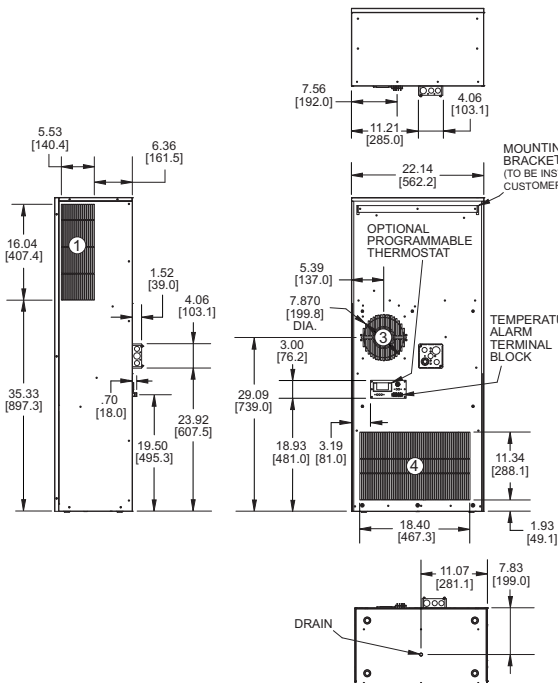
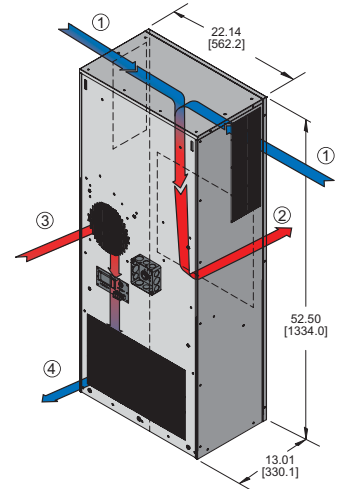

Many popular units are available as 3D solid models for customer system integration. Please contact Kooltronic for details.

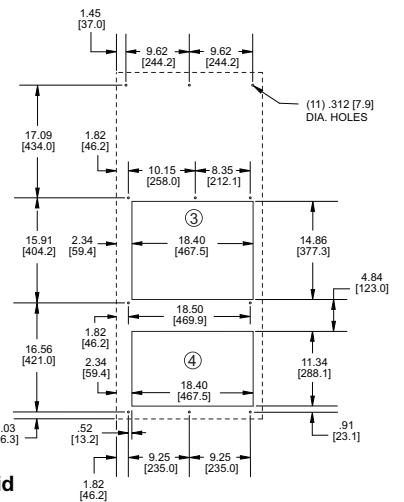

MOUNTING PLAN

Dimensions, inches [mm], are for reference only and are subject to change.

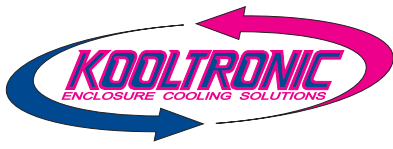

# GUARDIAN/GUARDIANX SERIES DP53 480 VOLT 3-PHASE NEMA 4 or 4X AIR CONDITIONERS

## DESCRIPTION

---

The **Guardian/GuardianX** Indoor/Outdoor Air Conditioners are designed specifically for **NEMA 4** and **4X** enclosure applications that require washdown or are subject to outdoor storm conditions. All **Guardian** models have a **NEMA 4** Rating, offering protection against the hazards of unwanted environmental penetration. The **GuardianX**, with the **NEMA 4X** Rating, is offered with a Stainless Steel Shell and Internal Corrosion Protection.

With Epoxy-coated condenser coils and a closed-loop cooling system, the **Guardian Series** offers added security by providing an operating environment safe from harsh ambient conditions.

The features engineered into all of the **Guardian Series** models make them a tamper-resistant choice for external applications. Combined with a NEMA 4 Rating, with all models UL/CUL Listed, the **Guardian Series** is an excellent choice for telecommunications or other outdoor cabinet applications.

## FEATURES AND BENEFITS (STANDARD)

---

All models UL and cUL Listed, a standard of safety.

CFC-free refrigerant provides a zero ozone depletion potential.

Condenser blower controller installed in the refrigerant liquid line, controlling the condenser fan.

Closed-loop cooling provides stable temperature control while excluding dust and humidity from the electrical enclosure.

Condenser impeller cycling provides stable capacity and temperature control.

Condenser filtration to maintain peak thermal performance extends compressor life.

Internal corrosion protection to increase reliability in hostile environments.

Low Temperature Control Thermostat provides energy-efficient operations.

NEMA 12, 3R & 4 ratings for compatibility with listed electrical enclosures.

Stainless steel shell for NEMA 4X corrosive environments (NEMA 4X models).

Both evaporator and condenser coils are epoxy coated, prolonging unit life.

## FEATURES AND BENEFITS (OPTIONAL)\*

---

Compressor short-cycling protection extends compressor life. (Standard Feature on models with a Programmable Thermostat).

Enclosure heater eliminates damaging condensation, increasing reliability of electrical enclosure components.

Lead-lag control for two air conditioners provides for capacity control, and alternates usage, increasing reliability.

Mounting adapter plates are offered to replace another manufacturer's unit.

Programmable thermostat capable of remote monitoring and control is available.

Programmable temperature alarm to alert if early action required.

Remote monitoring provides temperature data for warning of early action required.

Remote thermostat relay for control by a user-supplied control system.

### Special paint finishes\*

\*Contact KOOLTRONIC for more information.

## REPLACEMENT FILTERS

---

The DP53L-LV filter Part No. 6382F (16.88" x 6.38" x 0.34" [428.7mm x 162.0mm x 8.6mm]). The DP53L-LV uses two filters.